

# SOPRADOR DE MEMBRANA



Produto  
Pronta Entrega

Entre em  
**contato** conosco!

(19) 99887-4150  
vendas@ebsv.com.br





## EBS Serie / EBS series

EBS-S-60 / EBS-S-80 / EBS-S-100 / EBS-S-120

### Produktmerkmale

- Kompaktes Design
- Energieeffizient
- Schutzschalter inklusive
- Optional auch mit Signalkabel
- Schlauchstück im Lieferumfang
- Metallgehäuse

### Product characteristics

- Compact design
- Low energy consumption
- Protective switch inclusive
- Optional with signal cable
- Connecting hose incl. in delivery
- metal housing

## Abmessungen / Dimensions

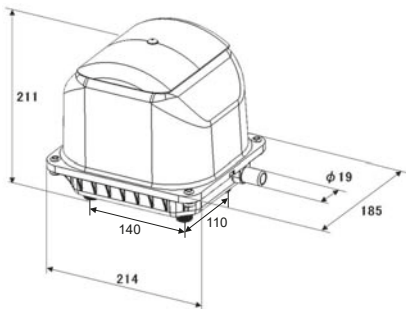

## Technische Daten / Technical data

Modell / Model		EBS-S-60	EBS-S-80	EBS-S-100	EBS-S-120	
Volumenstrom <sup>1)</sup> / Air flow <sup>1)</sup>	l/min	0 mbar	130	145	150	190
		50 mbar	125	130	145	180
		100 mbar	105	115	130	160
		150 mbar	85	90	110	140
		200 mbar	60	75	95	120
Spannung <sup>2)</sup> / Voltage <sup>2)</sup>	VAC	230				
Leistungsaufnahme / Power consumption	W	200 mbar	40	50	75	95
Geräuschpegel / Noise level	dB(A)		≤ 36	≤ 38	≤ 42	≤ 45
Abmessungen / Dimensions	mm	L x B x H L x W x H	214 x 185 x 211			
Schlauchanschluss / Connection	mm	Ø außen Ø outside	19			
Nettogewicht / Net weight	kg		6.5			

<sup>1)</sup> Die tatsächliche Leistung kann bis zu +/- 10% von den Angaben abweichen

<sup>2)</sup> Werte bei 50 Hz

<sup>1)</sup> Product performance may vary +/- 10% from performance curves

<sup>2)</sup> Values at 50/60 Hz

## Ersatzteile / Zubehör Spare Parts / Accessories

Ersatzteile / Spares	Bestell-Nr. / Code
Reparatur-Kit / Service Kit	K-JDK-60/80-D K-EBS-100/120-D
Membran-Set / Diaphragm Sets	D-EBS-60/120
Filter / Filter	FILTER-EBS-60/120
Magnet / Magnet	K-EBS-60/100-
Zubehör / Accessories	K-EBS-120-M
Manometer / Pressure Gauge	BP1 / 44M
Drucksicherheitsventil / Pressure Relief Valve	SE11

## Leistungsdaten / Performance data

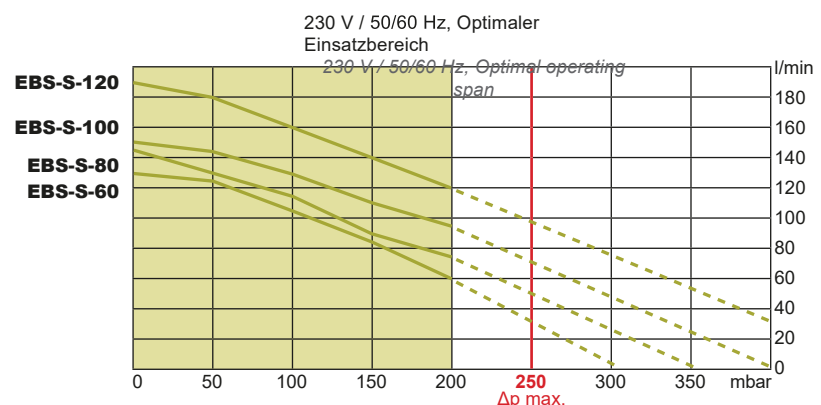



## EBS Serie / EBS series

EBS-S-150 / EBS-S-200 / EBS-S-250

### Produktmerkmale

- Kompaktes Design
- Energieeffizient
- Metallgehäuse

### Product characteristics

- Compact design
- Low energy consumption
- High quality metal housing

## Abmessungen / Dimensions

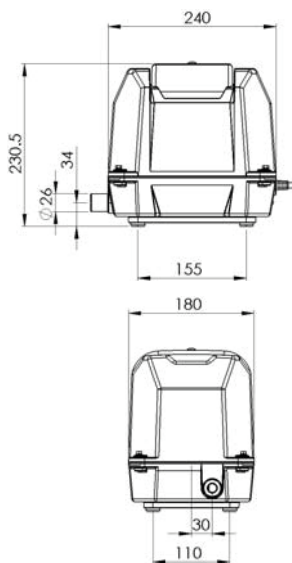

## Technische Daten / Technical data

Modell / Model		EBS-150	EBS-200	EBS-250	
Volumenstrom <sup>1)</sup> / Air flow <sup>1)</sup>	l/min	0 mbar	270	290	340
		50 mbar	240	270	325
		100 mbar	210	245	300
		150 mbar	180	220	270
		200 mbar	150	200	250
Spannung <sup>2)</sup> / Voltage <sup>2)</sup>	VAC	230			
Leistungsaufnahme / Power consumption	W	200 mbar	115	180	225
Geräuschpegel / Noise level	dB(A)	44	46	52	
Abmessungen / Dimensions	mm	L x B x H L x W x H	240 x 180 x 230.5		
Schlauchanschluss / Connection	mm	Ø außen Ø outside	26		
Nettogewicht / Net weight	kg	10			

<sup>1)</sup> Die tatsächliche Leistung kann bis zu +/- 10% von den Angaben abweichen

<sup>2)</sup> Werte bei 50 Hz

<sup>1)</sup> Product performance may vary +/- 10% from performance curves

<sup>2)</sup> Values at 50/60 Hz

## Ersatzteile / Zubehör Spare Parts / Accessories

Ersatzteile / Spares	Bestell-Nr. / Code
Reparatur-Kit / Service Kit	K-EBS-150/500-D
Membran-Set / Diaphragm Sets	D-EBS-150/500
Filter / Filter	FILTER-EBS-150/500
Magnet / Magnet	EBS-150/200-3
<b>Zubehör / Accessories</b>	
Manometer / Pressure Gauge	BP1 / 44M
L-Schlauchstück mit Drucksicherheitsventil / L-Typehose with pressure relief valve	SE45-L

## Leistungsdaten / Performance data

